

Equipment winding - unwinding

French Manufacturer of expansible airshafts - Safety chucks - Brakes - Spreader rolls

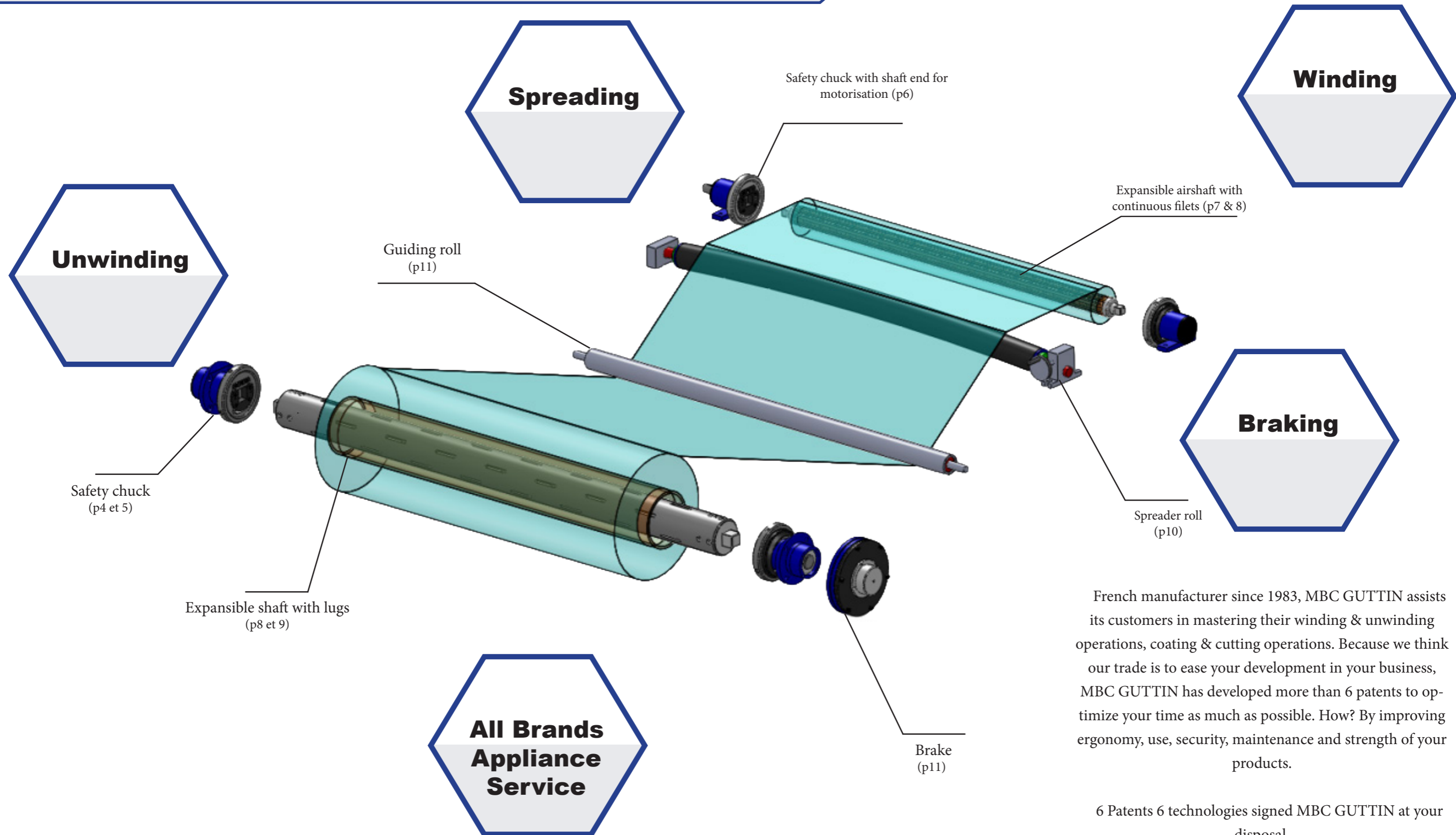

MECHANISM
BLOCKING
CONTROL



French manufacturer since 1983, MBC GUTTIN assists its customers in mastering their winding & unwinding operations, coating & cutting operations. Because we think our trade is to ease your development in your business, MBC GUTTIN has developed more than 6 patents to optimize your time as much as possible. How? By improving ergonomy, use, security, maintenance and strength of your products.

6 Patents 6 technologies signed MBC GUTTIN at your disposal.

SAFETY CHUCKS

Benefits

Made in France

100 % steel

To be mounted instead any installation :
replacement – custom made - repair

Safety

A chuck that closes itself !

A chuck that protects from everyday little accidents !

A chuck with several options for your safety & different types of locking systems (p6)



The MBC safety chucks (Mechanism Blocking Control) were designed to achieve all your winding & unwinding operations. Its automatic locking system protects in the event of an accident. Discover all our designs and find the solution that best suits your needs.

Patents MBC



Easier maintenance

A chuck design to optimize your maintenance time.
Gain nearly 15 minutes on the change of your wear parts.

7 screws and a disassembly only by the front face !

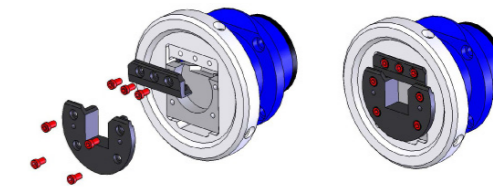

Easier maintenance

Disassembly of steering wheel axis and the locking ball becomes simply as child's play.

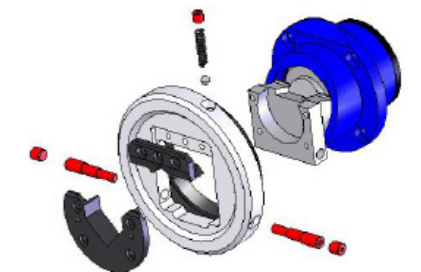

Design

Design of the locking system made with a push button stronger, more secure, more ergonomic.

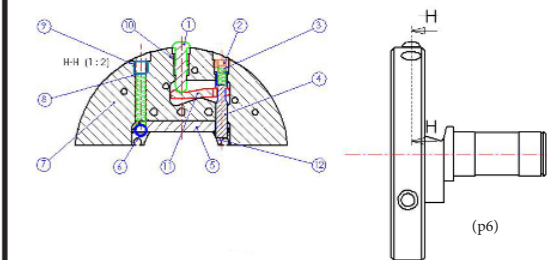

MODEL	REEL WEIGHT	TORQUE	SQUARE DIMENSION
14 – 20	150 kg	40 Nm	14 to 20 mm
18 – 25	400 kg	120 Nm	18 25 mm
20 – 30	800 kg	185 Nm	20 to 30 mm
30 – 40	1600 kg	350 Nm	30 to 40 mm
40 – 50	2850 kg	1 100 Nm	40 to 50 mm
50 – 80	7200 kg	2 350 Nm	50 to 80 mm
80 – 120	11 500 kg	9 000 Nm	80 to 120 mm
120 – 180	22 000 kg	20 000 Nm	120 to 180 mm
180 – 230	60 000 kg	40 000 Nm	180 to 230 mm

Available goods

Manual chuck

- Chuck with pivoting disc
- Chuck with sliding disc
- Translatory chuck, stroke 50 or 100 mm

Pneumatical chuck

- Pneumatical chuck simple or double effect
- Pneumatical selcentring and multifunction

Choice of options :

Choose your fixation type :



Foot
(serie 150)

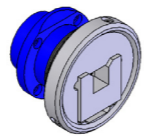
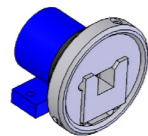

Flange
(serie 250)



Choose your shaft end (coupled to a motorisation or a braking system) :



Chuck with shaft end
= SFE/G

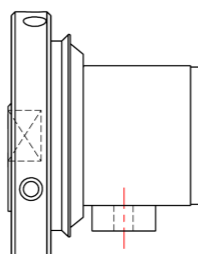
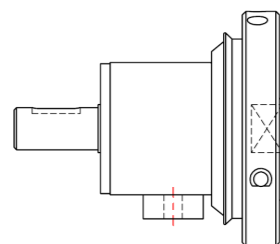

Chuck without shaft
end = SFE



If with shaft end, choose the type best suited for your application :

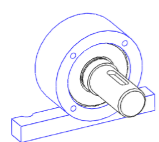

STD

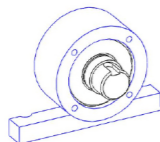

MD

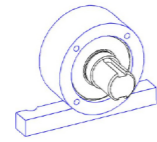

BD

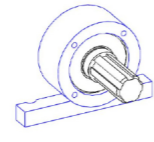

AC

Other
applications on
demand

Choose your geometry :

WITHOUT wear parts



Type A



Type E



Type B

WITH wear parts

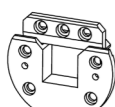

Type APU

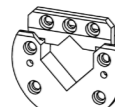

Type EPU

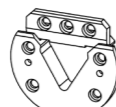

Type BPU

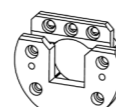

Type AVPU

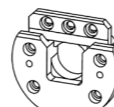

Type AWPU

Choose your anti opening system :

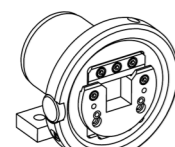

Type 1 - Left knurl

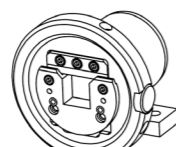

Type 1 - Right knurl

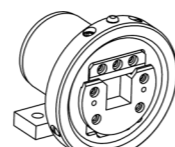

Type 2 - Push button

Patent MBC : Chuck serie 2000

Benefits

- Work at high speed
- No vibration
- Selfcentring of the shaft
- Multifunctions

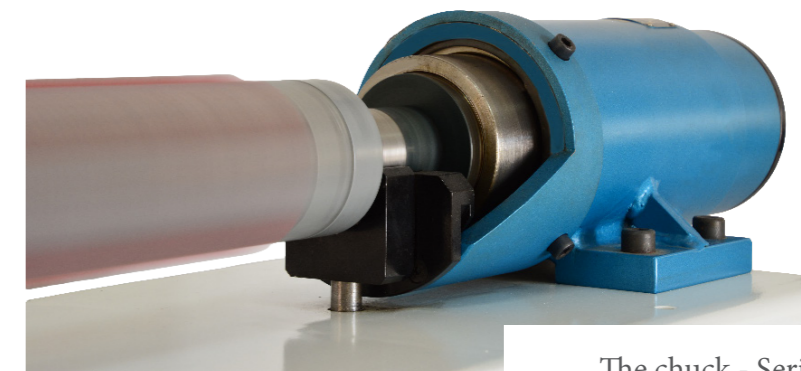

The chuck - Serie 2000 & 2100 is a pneumatical chuck which allows an ease of handling and enhances performances.

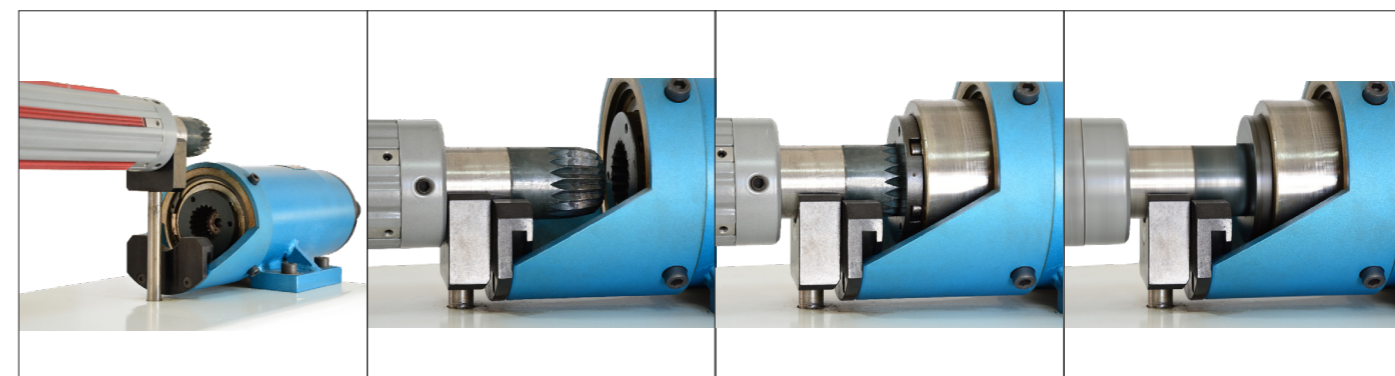

Step 1

Step 2

Step 3

Step 4

Install your shaft on the support Start your pneumatical system Thanks to its conical tip, the Serie 2000 collects and center automatically the shaft. The double conical tip avoids damaging effects on the notched end. Start rotation. You have now a rotation with no vibration which allows the work at very high speed, in safer conditions, with better performances.

Various options :

Smooth shaft support



Expansible head
with shells

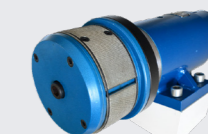

Shaft support with journal
bearing



Expansible head
with lugs



Benefits



Made in France
since 1983

Engineering Department
Custom made - Repairs

Lightness : MBC Guttin
thinks about your users !



R&D (Research & Development) of a
reinforced aluminium :
+ 35 % load
- 40% bending
for an equal weight to a standard
aluminium shaft

Choose your material :
Aluminium - Steel,
and only for shaft with lugs :
Carbon - reinforced Aluminium

Choose your expansion :
Rubber - Aluminium - Steel

Choose your expansion :
With lugs or continuous filets

Choose your shaft end :
Square - triangle - double
geometry or custom made.



Expandable airshafts allows the inside core
to mold the shaft and to exert winding &
unwinding operations.

Manufacturer, MBC offers expandable
airshafts from $\varnothing 1''$ (25.4 mm) up to $\varnothing 35''$ (900
mm) and up to 9 m length.

We carry out the desire shaft end with all
your specifications needed for your
application.

Patent MBC

Airshaft with lugs

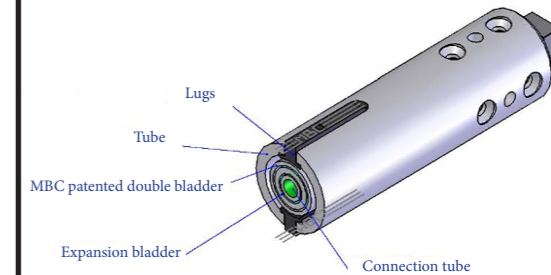

Strengthness

Protection of the bladder kit with the
«double skin».
Unique & patented by MBC Guttin.



Easier maintenance

Thanks to our double skin bladder, the
lugs remain in place !
You save 45 minutes when changind the
bladder kit.

Design

Airshaft with continuous filets

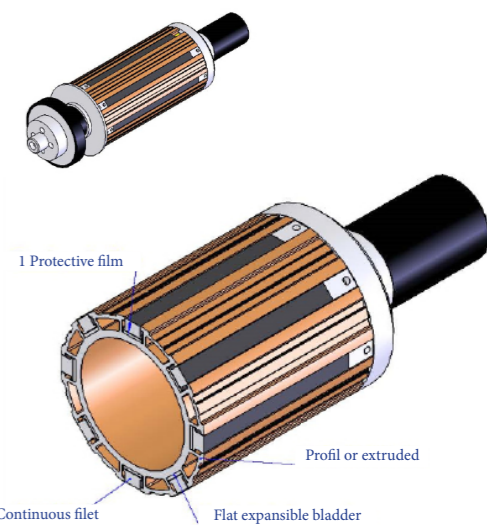

Expandible head



- Cantilevered work
- Rigidity & adaptability
- Stationary bar

Sleeve



- Fast rapid use
- Change of \varnothing if desired
- Easely switch from $\varnothing 74$ mm to $\varnothing 150$ mm

Airshaft with shells

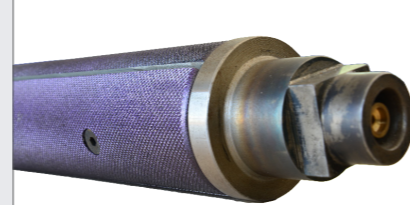

- Protects the final product
- Thin thickness cores
- Use without cores

Design for paper industry

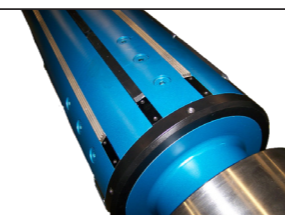

- Locking & centring continuous filets
- Static balancing of the tube
- 1750 m/ min - up to 15 tonnes

Friction bar

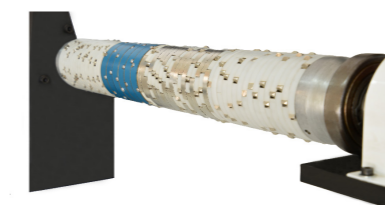

- Multitracks
- Friction rings (balls or pawls)
- Equal tension on each spool

SPREADER ROLLS

Obtain the best spreading system for your material.

A good spreading is obtained by the choice of an advisable material adapted to your product as well as the type of fold. MBC offers 4 kinds of spreader rolls, all specific to each application.

Curved spreader roll or Banana roll

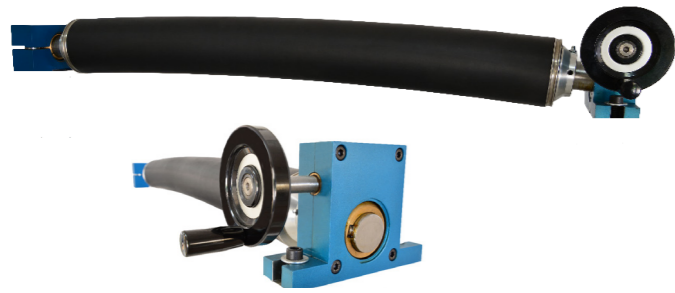

Spreader roll with stainless steel laths



Benefits

- Acts by deformation
- The most polyvalent of our spreader rolls (moisture, corrosive..)
- Different kinds of coating or fully made of stainless steel
- Fixed or variable curvature

Benefits

- Acts by spreading
- Advisable for heavy and delicate materials
- Different kinds of coating for the laths

Spreader rolls with ropes



Spiral spreader rolls (machinated or add-on)

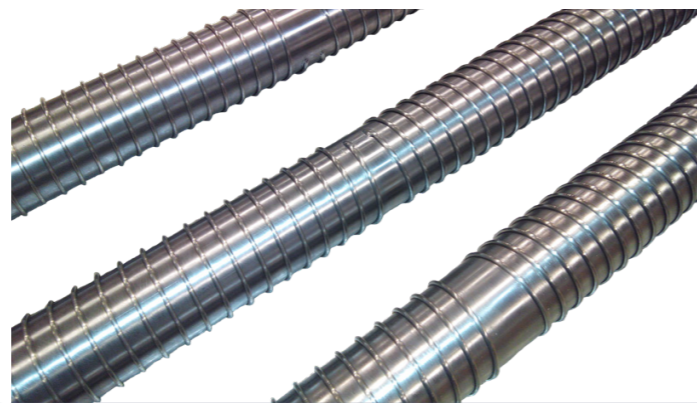

Benefits

- Acts by spreading
- Ideal for technical textiles & delicate materials
- Polyvalent (film, plastic...)
- Different kinds of ropes

Benefits

- Acts by spreading the material effortless
- To be mounted instead of guiding rolls
- Thickness & depth choices
- Available in aluminium, steel, stainless steel, rubber
- No maintenance

BRAKES

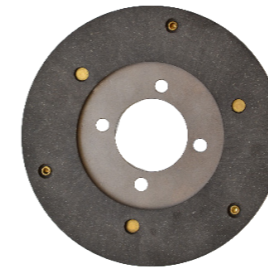

Master the tension of your product thanks to our MBC braking system. At MBC we offer a ferodo brake, manual or pneumatical, made in France, fitting all your applications.

Even more accuracy? We also have multi-piston and electrical brakes. Do not hesitate to contact us !

Power	∅A	L
40 Nm	145	100
70 Nm	220	100
480 Nm	300	100

Mono-disc

Power	∅A	L
90 Nm	145	125
180 Nm	220	125
900 Nm	300	125

Bi-disc

MANUAL BRAKE

MBC Guttin

Power	∅A	L
40 Nm	145	125
70 Nm	220	125
480 Nm	300	125

Mono-disc

Power	∅A	L
90 Nm	145	145
180 Nm	220	145
900 Nm	300	145

Bi-disc

PNEUMATICAL BRAKE

MBC Guttin

Miscellaneous

- Anti-static Material
- Tension Control

Guiding roll



Support base axial and or radial adjustment for chuck

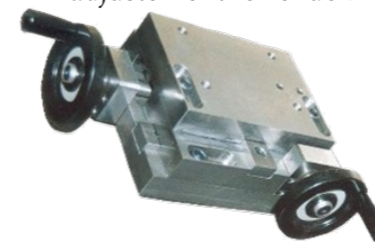

Mechanical head expansion with torque

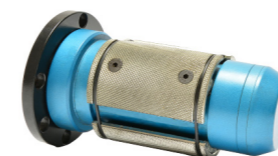

Trolley and/or frame design



Mechano pneumatical or manual reel riser



Mechanical head with axial thrust

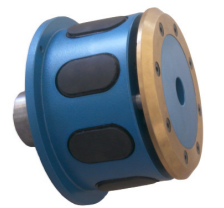

Shaft with bearing case for cantilevered unloading



Fiberglass Core

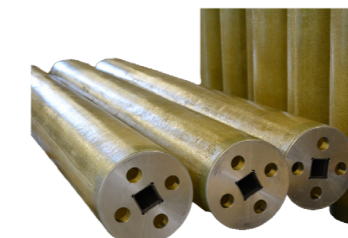

Aluminium locking cones



GLOBAL PRESENCE

50 Route du Charmay - 38490 CHARANCIEU
Tél : + 33 (0) 4 76 32 07 82 - Fax : + 33 (0) 4 76 32 29 56
www.guttin.com - mbc@guttin.com



Management

Fabrice et Stéphane GUTTIN

Administrative

Isabelle LECUYER

Compagny Fonder & Consultant

Christian GUTTIN

Sales

Pierre CLAUDON
+ 33 (0) 6 61 30 15 83
Patrick CREUSET
+ 33 (0) 6 61 30 07 83

Assistant Export
Jessica PLANTARD
+ 33 (0) 4 76 32 07 82

Administrative & Accounting Dpt. :

Stéphane GUTTIN
Marie -Blanche GUTTIN

Technical

Fabrice GUTTIN

Technical & After sales
Aimé CHEGUT

Quality & Production Manager
Gérard REYNAUD

— Ours agents —



SWITZERLAND

LATTY
DICHUNGSTECHNIK AG

(tel) 0041 62 752 20 84
(fax) 0041 62 752 23 69
latty@bluewin.ch



NETHERLANDS

OPENSUPPLY B.V.
Mr Erik FRANKE

(tel) 0031 541 700 260
(fax) 0031 541 744 025
erik@opensupply.eu



USA

LOUIS P. BATSON
Incorporated
Mr Chuck WITHINGTON

(tel) 001 864 242 5262
(fax) 001 864 271 4535
chuckw@lpbatson.com



GREAT BRITAIN

[Coming next]



GERMANY

BS INDUSTRIEVERTRETUNG
Mr Burkhard SHAAB

(tel) 0049 70 31 74 49 46
(fax) 0049 70 31 60 49 65
info@bs-industrie.de



GERMANY

SOLID COMPONENTS AG
Mr Felix EBERHARDI

(tel) 0049 21 91 56 118 62
(fax) 0049 21 91 51 775
f.eberhardi@robust.de



SPAIN

BARBANY Maquinaria Textil
Mr Rodolf BARBANY

(tel) 0034 93 450 16 87
(fax) 0034 93 347 84 54
info@barbany.com



AUSTRIA

HENNLICH Gmbh & Co KG
Mr Andreas HOCHHOLD

(tel) 0043 7712 3163 0
(fax) 0043 7712 3163 24
andreas.hochhold@hennlich.at