

MONO-DISQUE

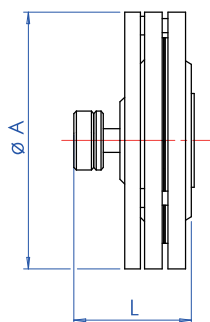

PUISSANCE	$\varnothing A$	L
40 Nm	145	100
70 Nm	220	100
480 Nm	300	100



BI-DISQUES

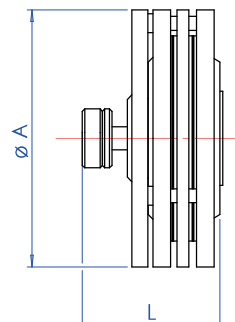

PUISSANCE	$\varnothing A$	L
90 Nm	145	125
180 Nm	220	125
900 Nm	300	125

**FREIN MBC MANUEL**

M.D.M : Mono-disque manuel

B.D.M : Bi-disques manuel

**MBC**  
*Guttin*

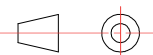

Freins pneumatique mono-disque

Freins pneumatique bi-disques

MONO-DISQUE

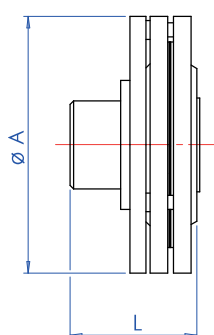

PUISSANCE	$\varnothing A$	L
40 Nm	145	125
70 Nm	220	125
480 Nm	300	125



BI-DISQUES

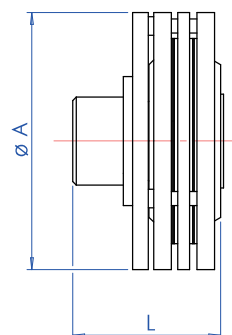

PUISSANCE	$\varnothing A$	L
90 Nm	145	145
180 Nm	220	145
900 Nm	300	145

**FREIN MBC PNEUMATIQUE**

M.D.P : Mono-disque pneumatique

B.D.P : Bi-disque pneumatique

**MBC**  
*Guttin*



## MONO-DISQUE

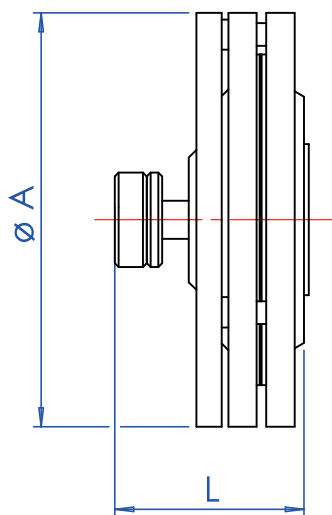

PUISSANCE	$\varnothing A$	L
40 Nm	145	100
70 Nm	220	100
480 Nm	300	100



## BI-DISQUES

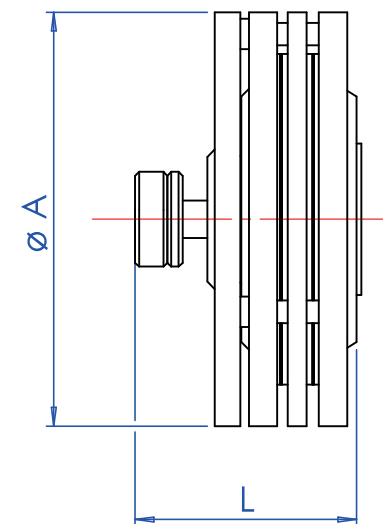

PUISSANCE	$\varnothing A$	L
90 Nm	145	125
180 Nm	220	125
900 Nm	300	125

## **FREIN MBC MANUEL**

M.D.M : Mono-disque manuel

B.D.M : Bi-disques manuel

*MBC*  
*Guttin*

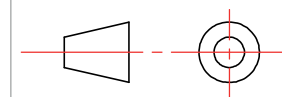

## MONO-DISQUE

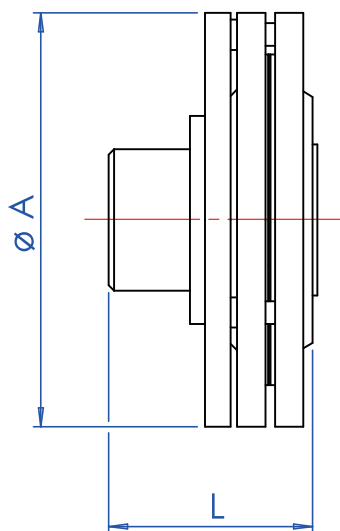

PUISSANCE	$\varnothing A$	L
40 Nm	145	125
70 Nm	220	125
480 Nm	300	125



## BI-DISQUES

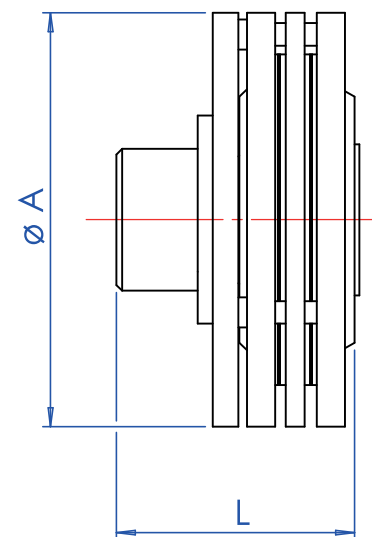

PUISSANCE	$\varnothing A$	L
90 Nm	145	145
180 Nm	220	145
900 Nm	300	145

### FREIN MBC PNEUMATIQUE

M.D.P : Mono-disque pneumatique

B.D.P : Bi-disque pneumatique

*MBC*  
*Guttin*

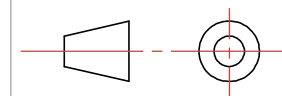

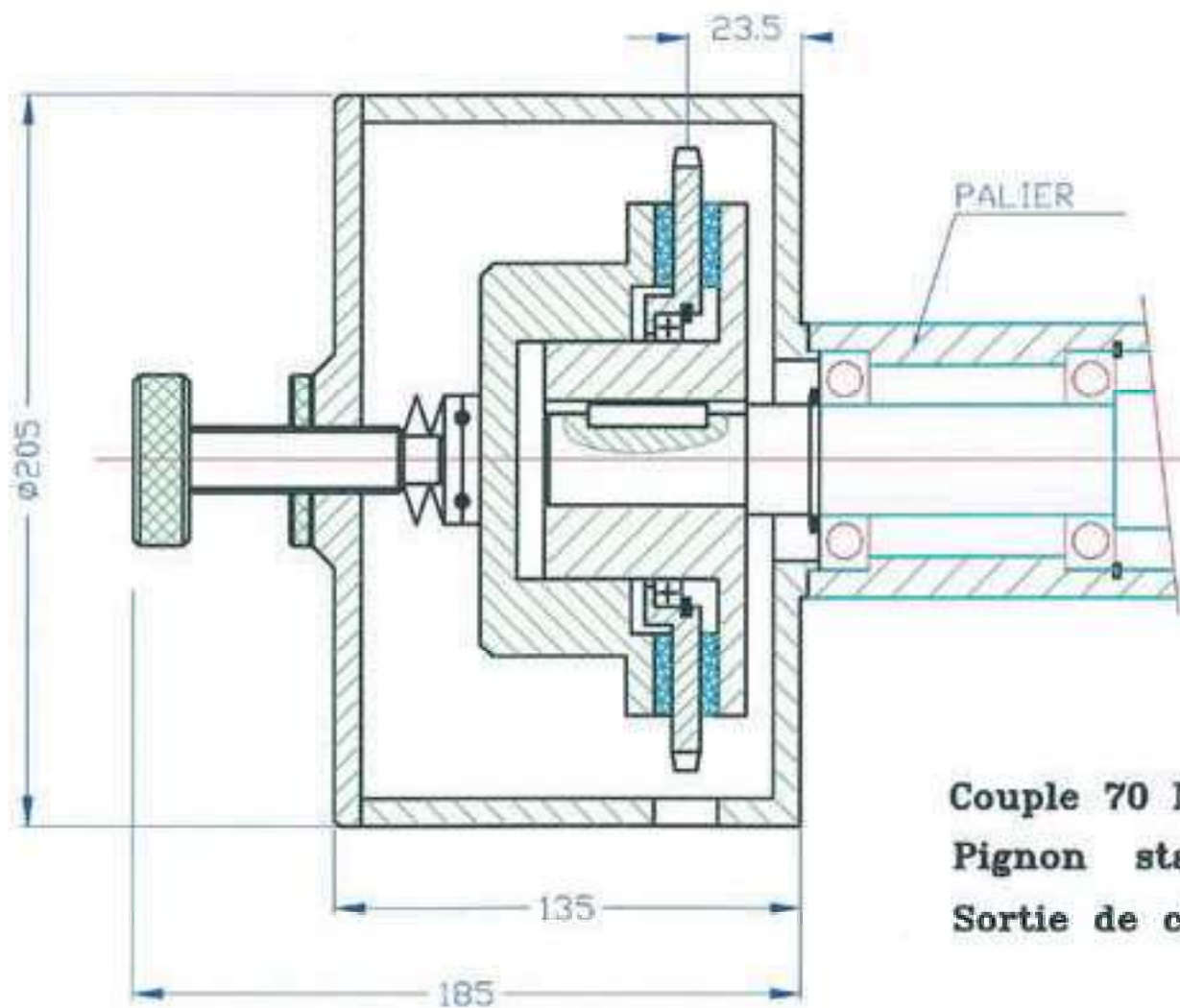

**Couple 70 Nm**

**Pignon standard 1/2" 40 dents**

**Sortie de chaîne : à préciser**

PALIER VERROUILLAGE AUTOMATIQUE

FRICION REGLAGE MANUEL POUR

PALIER 20/30-30/40-40/50

REF : MDM/F 70 Nm

*MBC*  
*Guttin*



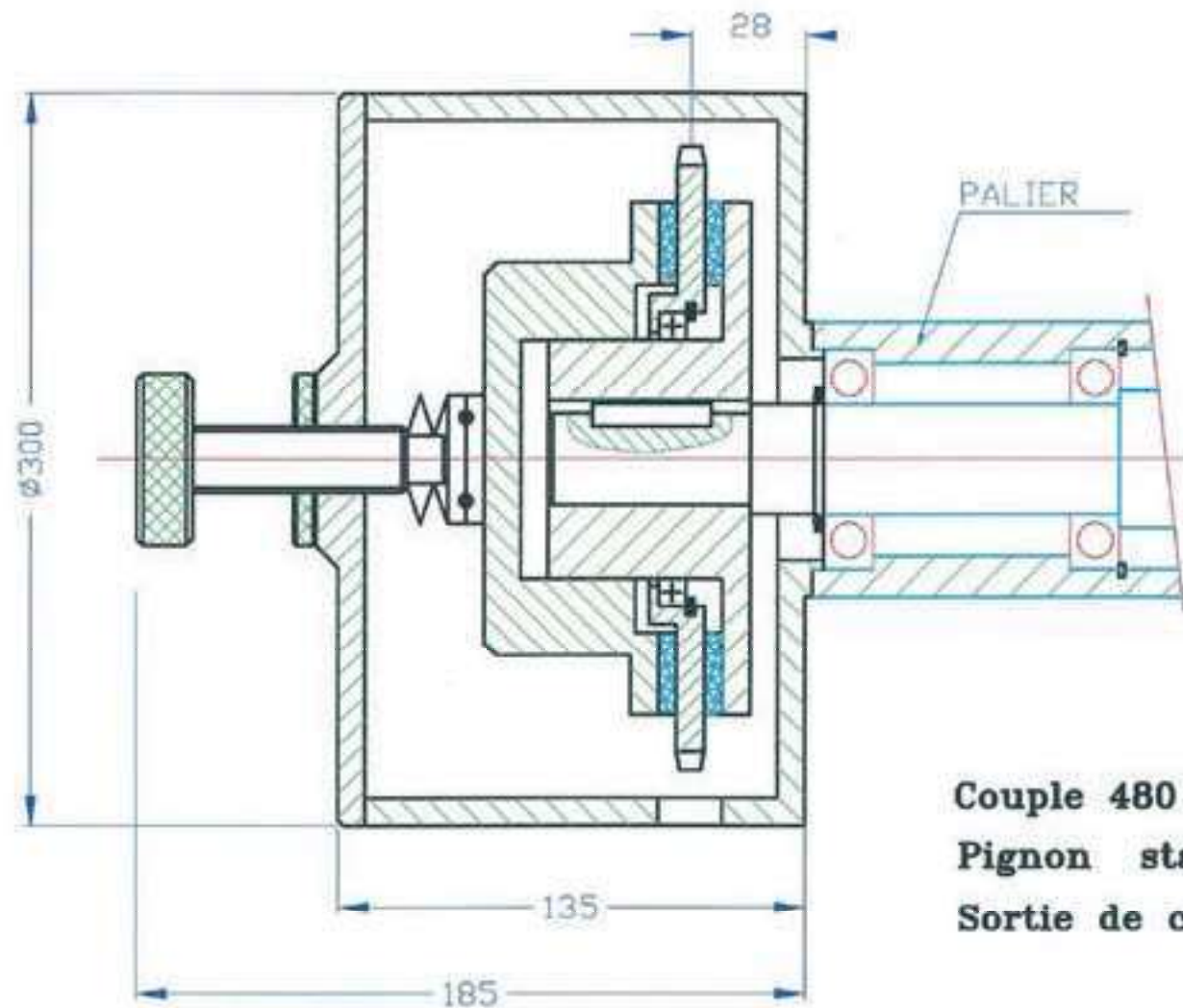

**Couple 480 Nm**

**Pignon standard 1/2" 70 dents**

**Sortie de chaîne : à préciser**

PALIER VERROUILLAGE AUTOMATIQUE

FRICION REGLAGE MANUEL POUR

PALIER 20/30-30/40-40/50

REF : MDM/F 480 Nm

*MBC*  
*Guttin*

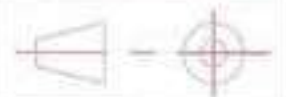

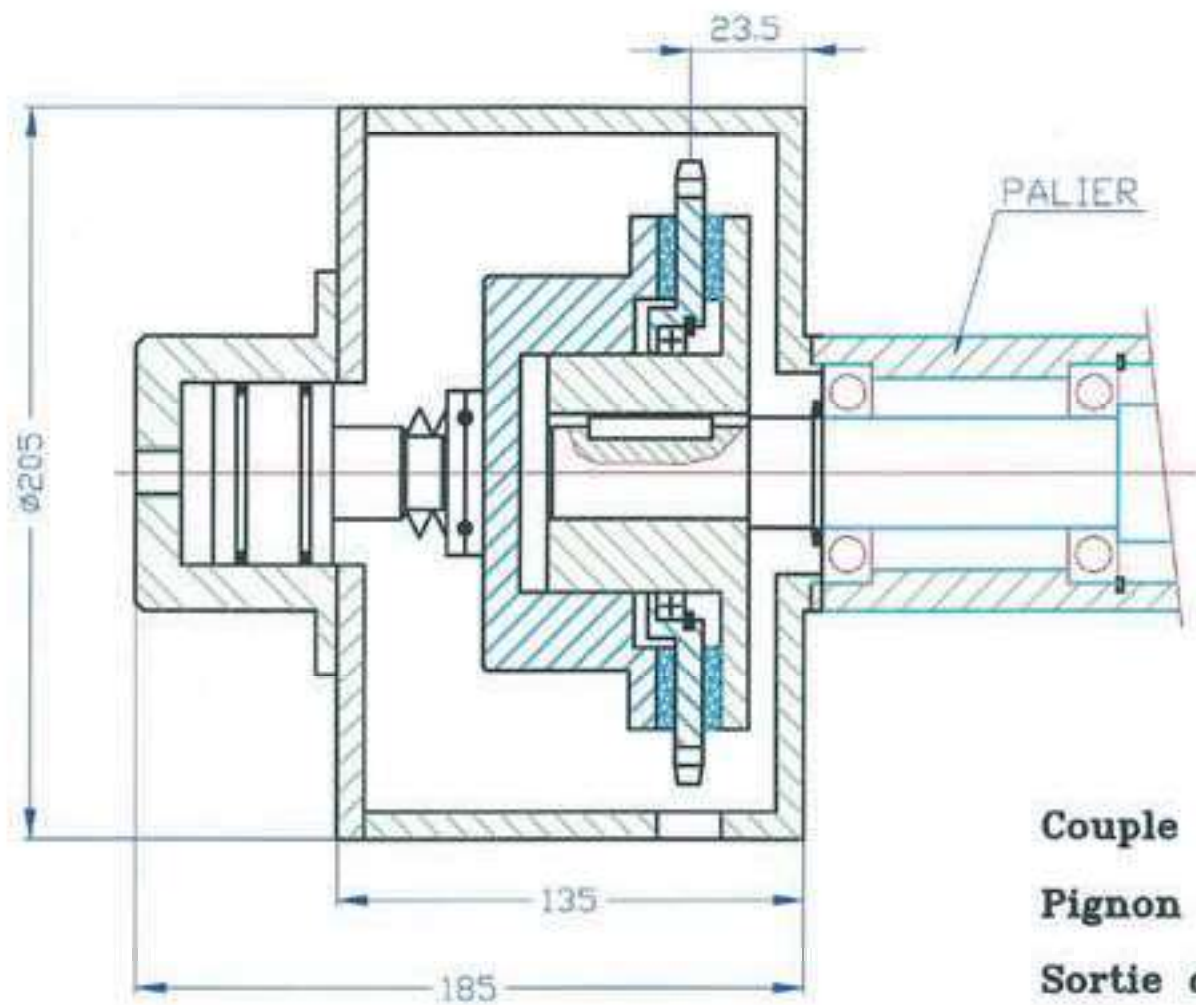

**Couple 70 Nm**

**Pignon 1/2" 40 dents**

**Sortie de chaîne : à préciser**

PALIER VERROUILLAGE AUTOMATIQUE

FRICITION REGLAGE PNEUMATIQUE

PALIER 20/30-30/40-40/50

REF : MDP/F 70 Nm

*MBC*  
*Guttin*



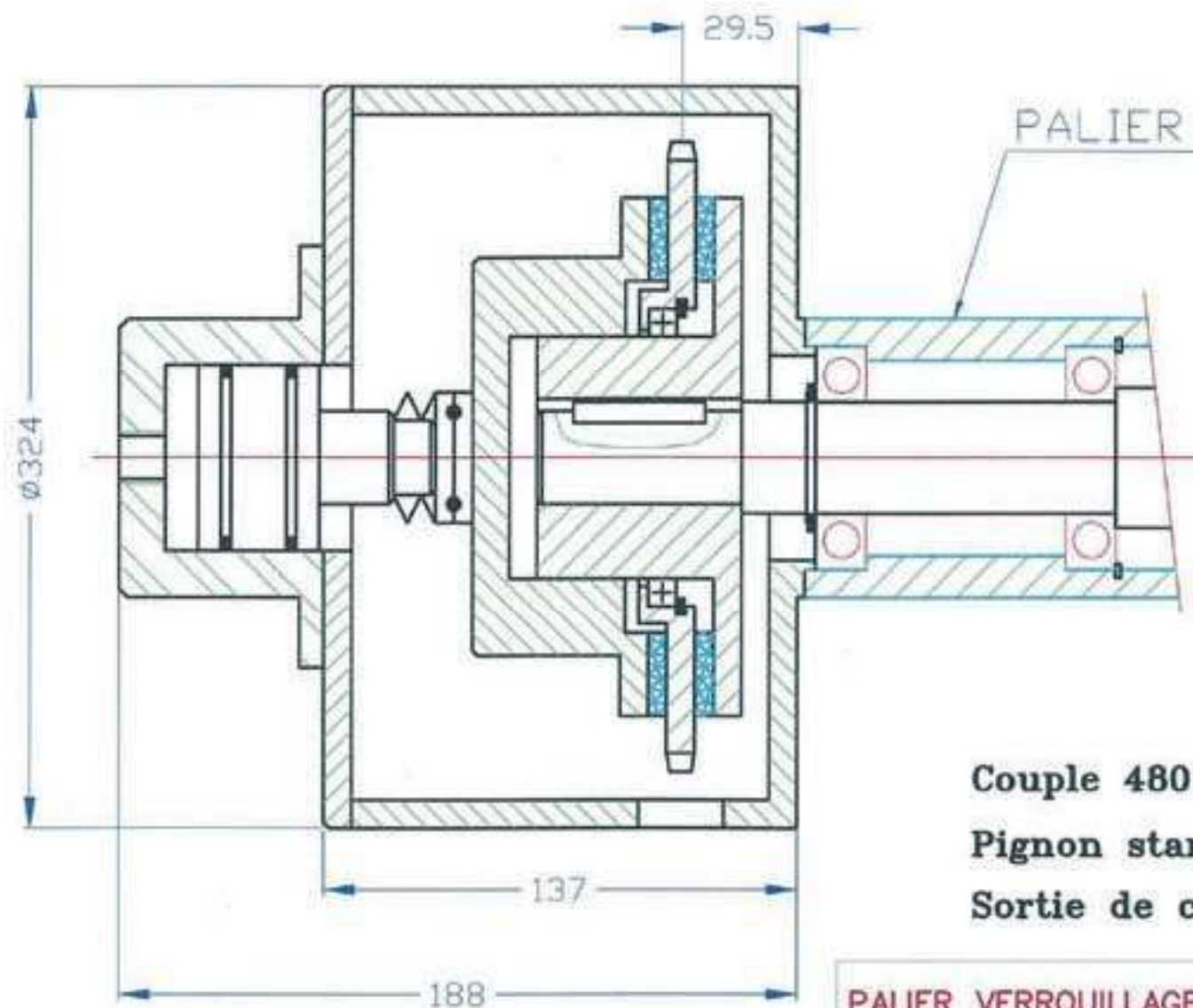

**Couple 480 Nm**

**Pignon standard 1/2" 70 dents**

**Sortie de chaîne : à préciser**

PALIER VERROUILLAGE AUTOMATIQUE

FRICION REGLAGE PNEUMATIQUE

PALIER 20/30-30/40-40/50

REF : MDP/F 480 Nm

*MBC*  
*Guttin*

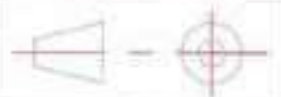

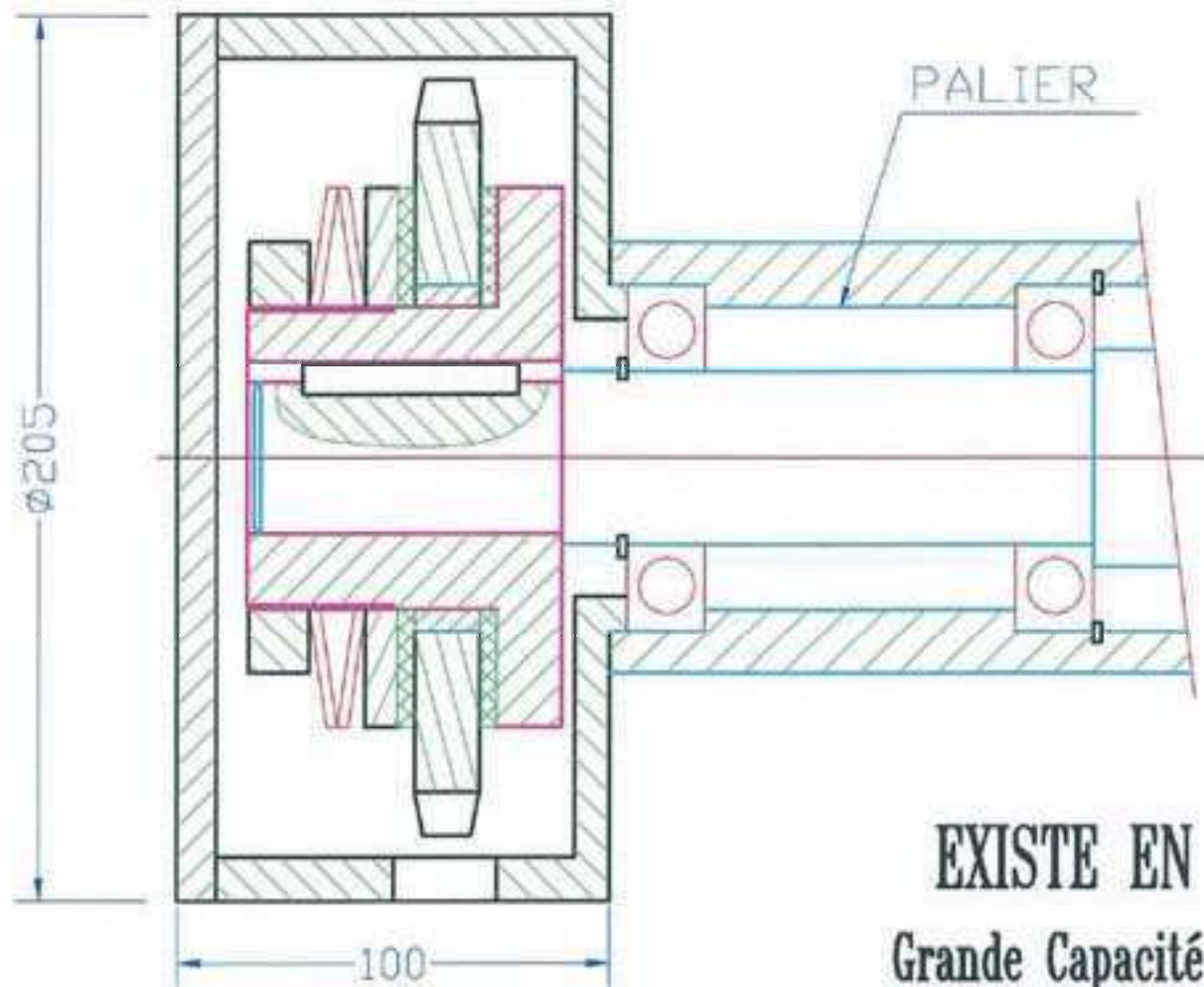

**EXISTE EN FRICTION**

**Grande Capacité couple 900 Nm**

**Couple 70 Nm**

**Pignon 1/2" 40 dents**

**Sortie de chaîne : à préciser**

**PALIER VERROUILLAGE AUTOMATIQUE**

**FRICTION REGLAGE MANUEL POUR**

**PALIER 20/30-30/40-40/50**

**REF : MDM/F2 70 Nm**

**MBC**  
**Guttin**

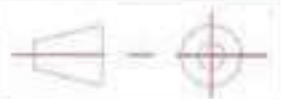

SYSTEME DE FREINAGE MONO-DISQUE  
 A REGLAGE PNEUMATIQUE (MDP/G)  
 COUPLE DE FREINAGE 70 Nm

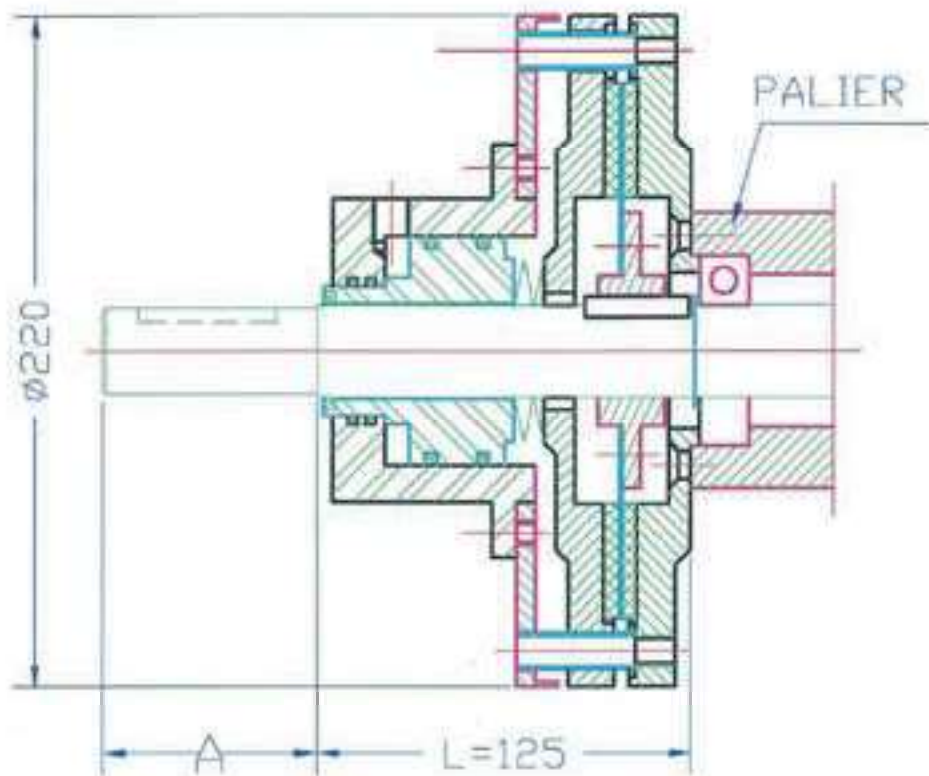

Cote A = standard palier MBC GUTTIN

SYSTEME DE FREINAGE BI-DISQUES  
 A REGLAGE PNEUMATIQUE (BDP/G)  
 COUPLE DE FREINAGE 180 Nm

L= + 20mm

PALIER VERROUILLAGE AUTOMATIQUE
FREIN MDP/G ou BDP/G 70Nm
POUR ARBRE MOTEUR FREINE
PALIER 20/30-30/40-40/50

*MBC*  
*Guttin*

